

GUMI KOMPENZATOR, PRIROBNIČNI / RUBBER FLEXIBLE JOINT, FLANGED

// Delovna temperatura / Working temperature: 0 °C /+100 °C

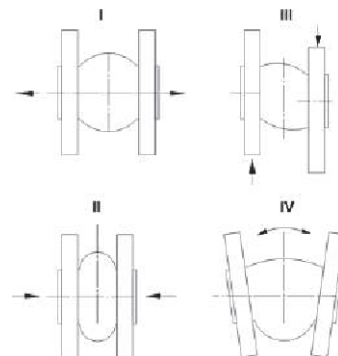
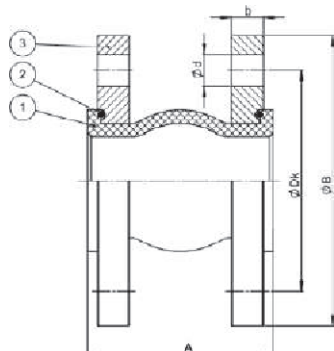

Materiali / Materials

1	Ohišje Body	EPDM
2	Žica Wire	Jeklo Steel
3	Prirobnica Flange	Ogljikovo jeklo Carbon steel

PN10

Art.	DN	A	ØB	b	ØDk	n-Ød	I	II	III	IV	Teža / Weight [kg]
A008696	32	95	140	16	100	4-18	6	9	9	15°	2,99
A008697	40	95	150	16	110	4-18	6	10	9	15°	3,63
A008698	50	105	165	18	125	4-18	7	10	10	15°	4,23
A008699	65	115	185	18	145	4-18	7	13	11	15°	5,36
A008700	80	135	200	20	160	8-18	8	15	12	15°	6,27
A008701	100	150	220	20	180	8-18	10	19	13	15°	6,94
A008702	125	165	250	22	210	8-18	12	19	13	15°	9,55
A008703	150	180	285	22	240	8-18	12	20	14	15°	12,95
A044006	200	205	340	24	295	8-22	16	25	22	15°	17,24
A044007	250	230	395	26	350	12-22	16	25	22	15°	23,75
A044008	300	245	445	26	400	12-22	16	25	22	15°	32,75
A008707	350	265	505	26	460	16-22	16	25	22	15°	41,3

PN16

Art.	DN	A	ØB	b	ØDk	n-Ød	I	II	III	IV	Teža / Weight [kg]
A008696	32	95	140	16	100	4-18	6	9	9	15°	2,99
A008697	40	95	150	16	110	4-18	6	10	9	15°	3,63
A008698	50	105	165	18	125	4-18	7	10	10	15°	4,23
A008699	65	115	185	18	145	4-18	7	13	11	15°	5,36
A008700	80	135	200	20	160	8-18	8	15	12	15°	6,27
A008701	100	150	220	20	180	8-18	10	19	13	15°	6,94
A008702	125	165	250	22	210	8-18	12	19	13	15°	9,55
A008703	150	180	285	22	240	8-18	12	20	14	15°	12,95
A008704	200	205	340	24	295	12-22	16	25	22	15°	17,24
A008705	250	230	405	26	355	12-22	16	25	22	15°	23,75
A008706	300	245	460	28	410	12-26	16	25	22	15°	32,75
A044001	350	255	520	30	470	16-26	16	25	22	15°	42
A044002	400	255	580	32	525	16-30	16	25	22	15°	50
A044003	450	255	640	32	585	20-30	16	25	22	15°	62
A044004	500	255	715	34	650	20-33	16	25	22	15°	84
A044005	600	260	840	38	770	20-36	16	25	22	15°	105

Opombe

I – Raztezek v mm.

II – Skrčec v mm.

III – Strig v mm.

IV – Upogib v stopinjah.

Številke artiklov od DN32–DN150 so enake za PN10 in PN16 in so vedno navedene kot PN16.

Notes

I – Elongation in mm

II – Compression in mm

III – Lateral deflection in mm

IV – Angular deflection in deg

Article numbers for DN32–DN150 are the same for PN10 and PN16 and are always declared as PN16.

GUMI KOMPENZATOR, NAVOJNI / RUBBER FLEXIBLE JOINT, THREADED

// Delovna temperatura / Working temperature: 0 °C /+100 °C

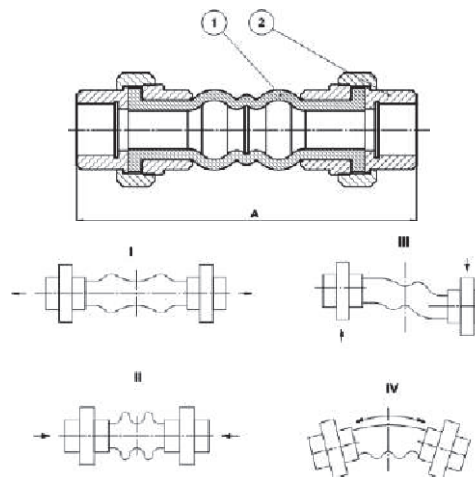

Materiali / Materials

1	Ohišje Body	EPDM
2	Holandec Union	Pocinkana siva litina – EN-GJL-250 (GG25) Galvanized Cast Iron – EN-GJL-250 (GG25)

PN16

Art.	DN	A	I	II	III	IV	Teža / Weight [kg]
A030892	20 3/4"	200	5	22	22	30°	0,75
A030893	25 1"	200	5	22	22	30°	1,23
A030895	32 1 1/4"	200	5	22	22	30°	1,51
A030894	40 1 1/2"	200	5	22	22	30°	2,1
A030896	50 2"	200	5	22	22	20°	2,71
A030897	65 2 1/2"	240	8	24	24	15°	3,98
A030898	80 3"	240	8	24	24	15°	5,7

Opombe

I – Raztezek v mm.
II – Skrček v mm.
III – Strig v mm.
IV – Upogib v stopinjah.

Notes

I – Elongation in mm
II – Compression in mm
III – Lateral deflection in mm
IV – Angular deflection in deg